

UM01509

LoRaWAN Module RHF76-052 User Manual

V2.6

Document information

Info	Content
Keywords	<i>LoRaWAN, RHF76-052, AT Command, UART, USB</i>
Abstract	This document shows how to use RisingHF LoRaWAN module RHF76-052 set up a LoRa/LoRaWAN node, and defines AT command format used by the module

Content

Content.....	2
Tables.....	5
Figures.....	5
Part I-RHF76-052 Hardware description.....	1
1 Introduction of RHF76-052.....	1
2 Electrical Characteristics.....	1
2.1 Absolute Maximum Ratings.....	1
2.2 Operating Range.....	1
2.3 Module Specifications.....	1
2.4 GPIO Definition.....	2
3 Hardware Design Reference.....	4
4 Package Information.....	6
4.1 Package Information.....	6
5 Application in LoRaWAN.....	7
2.1 LoRaWAN/LoRaMAC.....	7
2.2 RHF76-052 with LoRaWAN.....	8
Part II-AT Command Specifications.....	10
6 Introduction of AT Command.....	10
6.1 Feature.....	10
6.2 Related Products.....	10
7 Essential informations before using AT command.....	11
7.1 Conventions.....	11
7.2 Symbols.....	11
7.3 Format.....	11
7.3.1 Query.....	11
7.3.2 Configure / Control.....	11
7.3.3 Return.....	11
7.4 Error.....	12
7.5 EEPROM.....	12
7.6 Payload Length Limitation.....	13
8 AT Commands description.....	14
8.1 AT.....	15

8.2 ID.....	15
8.3 RESET.....	16
8.4 MSG.....	16
8.5 CMSG.....	16
8.6 MSGHEX.....	17
8.7 CMSGHEX.....	17
8.8 PORT.....	18
8.9 ADR.....	18
8.10 DR.....	18
8.10.1 Datarate Scheme.....	18
8.10.2 Customized Data Rate Scheme.....	21
8.11 CH.....	22
8.12 POWER.....	23
8.13 REPT.....	23
8.14 RXWIN2.....	24
8.15 RXWIN1.....	24
8.16 VER.....	25
8.17 KEY.....	25
8.18 FDEFAULT.....	25
8.19 DFU.....	26
8.20 HELP.....	27
8.21 MODE.....	28
8.22 JOIN.....	28
8.23 CLASS.....	29
8.24 LOWPOWER.....	29
8.25 TEST.....	30
8.25.1 Print Help Information.....	30
8.25.2 Enter TEST mode.....	30
8.25.3 Query RF configuration.....	30
8.25.4 Set RF Configuration.....	31
8.25.5 TX LoRa Packet.....	32
8.25.6 RX LoRa Packet.....	32
8.25.7 TX Continuous Wave.....	33

8.25.8 TX Continuous LoRa.....	33
8.25.9 RSSI.....	33
8.25.10 LWDL.....	33
8.26 UART.....	33
8.26.1 TIMEOUT.....	33
8.27 DELAY.....	34
Revision.....	35

Tables

Table 2-1 Absolute Maximum Ratings.....	1
Table 2-2 Operating Range.....	1
Table 2-3 Module Specifications.....	1
Table 2-4 GPIO description.....	2
Table 4-1 Related products list.....	10
Table 5-1 Error code list.....	12
Table 5-2 Memorized configuration.....	12
Table 5-3 Payload length limitation.....	错误! 未定义书签。
Table 6-1 Command List.....	14
Table 6-2 LoRaWAN EU868 Data Rate Scheme.....	20
Table 6-3 LoRaWAN US915 Data Rate Scheme.....	20
Table 6-4 Factory default configuration.....	26
Table 6-5 TEST mode sub-command list.....	30
Table 6-6 MAX output power of HF and LF band.....	31
Table 6-7 LoRaWAN Delay Items.....	34

Figures

Figure 3-1 RHF76-052 AM Reference Design (FW upgrade with UART).....	4
Figure 3-2 RHF76-052 AN Reference Design (FW upgrade with USB).....	5
Figure 4-1 package outline drawing.....	6
Figure 4-2 Recommended land pattern.....	7
Figure 5-1 Energy profile of RHF76-052 application in LoRaWAN.....	8
Figure 5-2 Energy profile of RHF76-052 application in LoRaWAN.....	9

Part I-RHF76-052 Hardware description

1 Introduction of RHF76-052

RisingHF™ LoRaWAN™ module RHF76-052 is embedded with LoRaWAN stack. Customer could use a host MCU to control this modem with simple AT command. The advanced and simple command interface offers rapid time to market.

This part is targeted to help customer to set their hardware platform quickly with RHF76-052 modem.

2 Electrical Characteristics

2.1 Absolute Maximum Ratings

Stresses above the values listed below may cause permanent device failure. Exposure to absolute maximum ratings for extended periods may affect device reliability.

Table 2-1 Absolute Maximum Ratings

Item	Description	min	max	unit
VCCmr	Supply voltage	-0.3	+3.9	V
Tmr	Temperature	-55	+115	°C
Pmr	RF input level	-	+10	dBm

2.2 Operating Range

Table 2-2 Operating Range

Item	Description	min	max	unit
VCCop	Supply voltage	+1.8	+3.6	V
Top	Temperature	-40	+85	°C
Pop	RF input level	-	+10	dBm

2.3 Module Specifications

Table 2-3 Module Specifications

ITEMS	Parameter	Specifications	Unit
Structure	Size	23(W) X 28(L) X 2.6(H)	mm
	Package	33 pins, SMT	
Electrical Characteristics	power supply	3.3V type	V
	Sleep current	1.45uA	uA
	Operation current (Transmitter+MCU)	120mA @20dBm in 434MHz/470MHz type	mA
		45mA @14dBm in 868MHz/915MHz type	mA
	Operation current (Receiver+MCU)	16mA @BW125kHz, 434MHz/470MHz type	mA
15.5mA @BW125kHz, 868MHz/915MHz type		mA	
Output power	20dBm max @434MHz/470MHz	dBm	

		14dBm max @868MHz/915MHz	dBm
	Sensitivity	-139dBm @SF12, BW125kHz, 434MHz/470MHz	dBm
		-137dBm @SF12, BW125kHz, 868MHz/915MHz	dBm
	Harmonics (LF)	<-42dBm below 1GHz	dBm
		<-35dBm above 1GHz	dBm
Harmonics (HF)	<-40dBm above 1GHz	dBm	
Interface	RFIO_LF	RF port for Low Band (434MHz/470MHz)	
	RFIO_HF	RF port for High Band (868MHz/915MHz)	
	SPI	1 group of SPI, include 4 pins	
	USART	1 group of USART, include 2pins	
	USB	1 group of USB, include 2 pins	
	I2C	1 group of I2C, include 2 pins	
	ADC	2 ADC Input, include 2 pins	
	GPIOs	8 GPIOs more except the interface above	
	NRST	Manual reset pin input	

2.4 GPIO Definition

Table 2-4 GPIO description

Number	Name	Type	Description and application
1	VCC	-	Supply voltage for the module
2	GND	-	Ground
3	PA8	I/O	GPIO_PA8 ⁽²⁾
4	PA9	I/O	GPIO_PA9; UART1_TX of Modem for Firmware upgrade(RHF76-052AM)
5	PA10	I/O	GPIO_PA10; UART1_RX of Modem for Firmware upgrade(RHF76-052AM)
6	NSS	I/O	GPIO_PB12
7	SCK	I/O	GPIO_PB13
8	MISO	I/O	GPIO_PB14
9	MOSI	I/O	GPIO_PB15
10	USART1_CTS	I/O	USART1_CTS ⁽¹⁾ from MCU; GPIO_PA11; USB_DM for Firmware upgrade(RHF76-052AN)
11	USART1_RTS	I/O	USART1_RTS ⁽¹⁾ from MCU; GPIO_PA12; USB_DP for Firmware upgrade(RHF76-052AN)
12	SWDIO	I/O	SWDIO of SWIM for program download;

Number	Name	Type	Description and application
13	SWCLK	I/O	SWCLK of SWIM for program download;
14	PA15	I/O	Boot_EN (GPIO_PA15), Connect to a toggle switch to enable DFU mode for FW upgrade.
15	PB3	I/O	GPIO_PB3
16	PB4	I/O	Status LED (GPIO_PB4) trigger, connect to an external LED to show status of LoRaWAN processing
17	NC	-	Connected to Ground
18	NC	-	Connected to Ground
19	NC	-	Connected to Ground
20	PA3/ADC3	I/O	GPIO_PA3
21	PB5	I/O	Status LED (GPIO_PB5) trigger, connect to an external LED, Reserved
22	USART1_TX	I/O	USART1_TX of Modem, connect to RXD of Host MCU
23	USART1_RX	I/O	USART1_RX of Modem, connect to TXD of Host MCU
24	I2C_SCL	I/O	GPIO_PB8
25	I2C_SDA	I/O	GPIO_PB9
26	PC13/Wkup2	I/O	GPIO_PC13
27	NRST	I	Reset trigger input of Modem
28	PA0/AD0	I/O	GPIO_PA0
29	GND	-	Ground
30	RFIO_HF	-	RF input/output in high band, i.e. 868MHz/915MHz
31	GND	-	Ground
32	RFIO_LF	-	RF input/output in low band, i.e. 434MHz/470MHz
33	GND	-	Ground

Note: (1) Optional handshake lines are supported in future firmware releases.
 (2) GPIO couldn't be controlled by Host MCU by UART in current version.

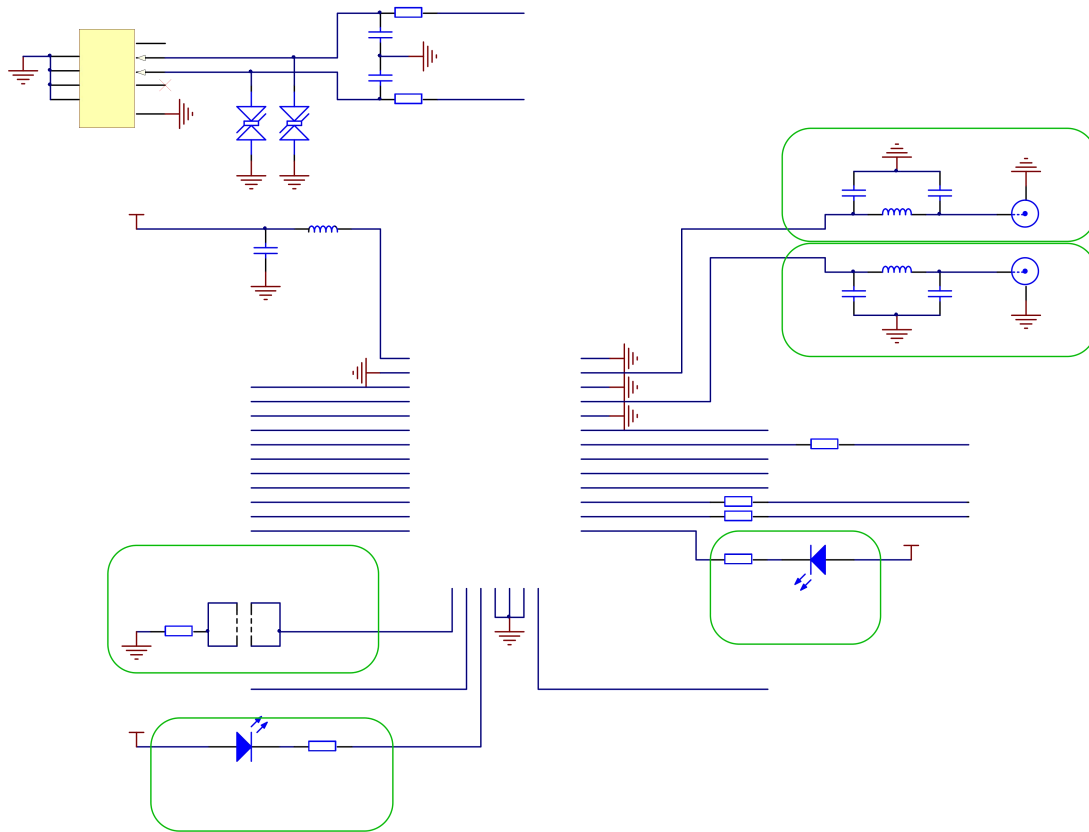

Figure 3-2 RHF76-052 AN Reference Design (FW upgrade with USB)

Hardware design description:

- 1) VCC operation range: +1.8V to +3.6V
- 2) Pin22 and Pin 23 of the Modem would be used as UART port, please connect to Host MCU. Pin22 should be connected to RXD of Host MCU, and Pin23 should be connected to TXD of Host MCU.
- 3) For **RHF76-52 AM**: Pin4 and Pin5 of the Modem would be used as FW upgrade port based on UART connection. Pin4 should be connected to RXD of Host, and Pin5 should be connected to TXD of Host.

For **RHF76-052 AN**: Pin10 and Pin11 of the Modem would be used as FW upgrade port based on USB CDC connection. Pin10 should be connected to USB_DM, and Pin11 should be connected to USB_DP.

- 4) Pin14 (GPIO_PA15) would be used to enable the DFU mode for FW upgrade. Please connect it to a toggle switch to achieve DFU enable function via a hardware way.

Note: Customer could also use a SW way with AT command to access into DFU mode.

- 5) Pin16 would be used to show LoRaWAN processing status. Please connect this pin to a LED if need.

This LED would blink when transmit or receive a message in LoRaWAN mode.

6) Pin21 would be used to be reserved for LED connection.

RHF76-052AM/AN UART modem support both low band (434MHz/470MHz) and high band (868MHz/915MHz). When use an internal antenna with mismatch impedance, a π topology for antenna matching is strongly suggested.

7) Antenna selection

Please use a 0dBi omnidirectional antenna in the design.

4 Package Information

4.1 Package Information

The RHF76-052 is available in a 33-lead SMD package as shown in Figure 4-1 below:

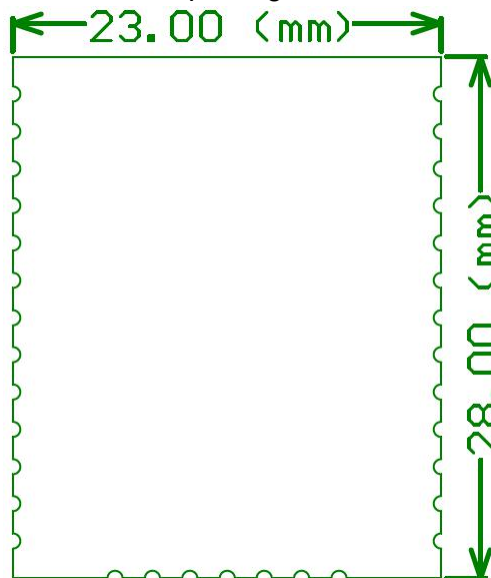

Figure 4-1 package outline drawing

Figure 4-2 show the recommended land pattern for layout.

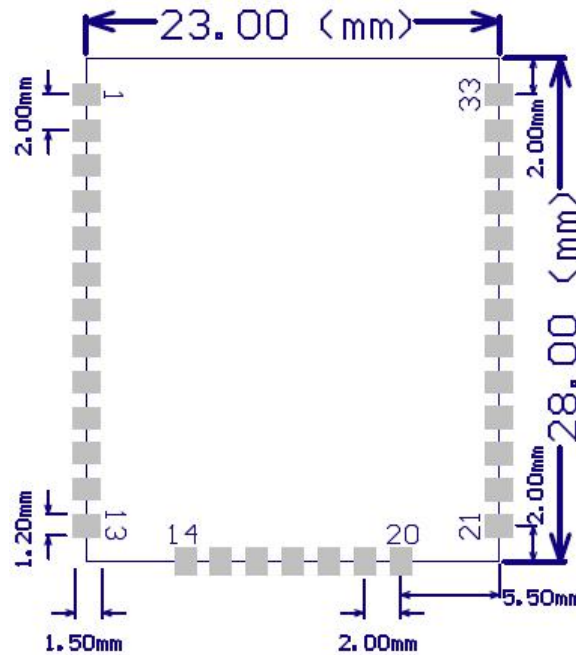

Figure 4-2 Recommended land pattern

5 Application in LoRaWAN

2.1 LoRaWAN/LoRaMAC

LoRaWAN networks typically are laid out in a star-of-stars topology in which gateways relay messages between end-devices and a central network server at the backend. Gateways are connected to the network server via standard IP connections while end devices use single-hop LoRa™ or FSK communication to one or many gateways. All communication is generally bi-directional, although uplink communication from an end device to the network server is expected to be the predominant traffic. Communication between end-devices and gateways is spread out on different frequency channels and data rates. The selection of the data rate is a trade-off between communication range and message duration, communications with different data rates do not interfere with each other. LoRa data rates range from 0.3 kbps to 50 kbps, with different Band Width and Spreading Factor. To maximize both battery life of the end-devices and overall network capacity, the LoRa network infrastructure can manage the data rate and RF output for each end-device individually by means of an adaptive data rate (ADR) scheme.

End-devices may transmit on any channel available at any time, using any available data rate, as long as the following rules are respected:

- 1) The end-device changes channel in a pseudo-random fashion for every transmission. The resulting frequency diversity makes the system more robust to interferences.
- 2) The end-device respects the maximum transmit duty cycle relative to the sub-band used and local regulations.

3) The end-device respects the maximum transmit duration (or dwell time) relative to the sub-band used and local regulations.

The RHF76-052 Module incorporates Semtech’s LoRa Chip SX1276 and ST’s ultra-low power MCU. With only 1.45uA sleep current in WOR mode, the module is really very suitable for LoRaWAN application.

2.2 RHF76-052 with LoRaWAN

The Figure 5- 1 and Figure 5-2 below show the power consumption of the RHF76-052 module. The code is organized so that the MCU and all peripherals are in sleep mode most of the time. In Figure 16, two RX windows will follow the TX window which is in accordance with LoRaWAN protocol. In the RX window1, the SF of the receiver would set to SF12 for example (should be same as the SF when transmit before).When there is no packet received in the RX window1, the RX window2 would occur. In the RX window2, the SF of the receiver would set to SF9.

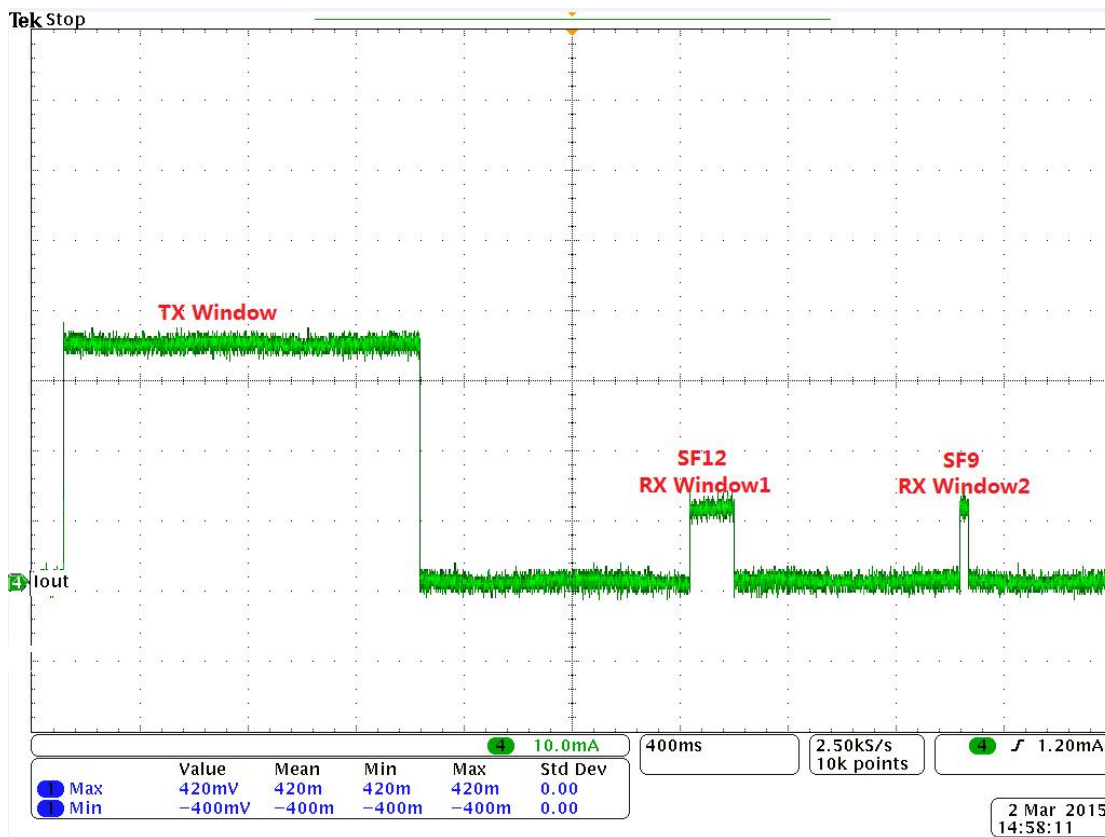
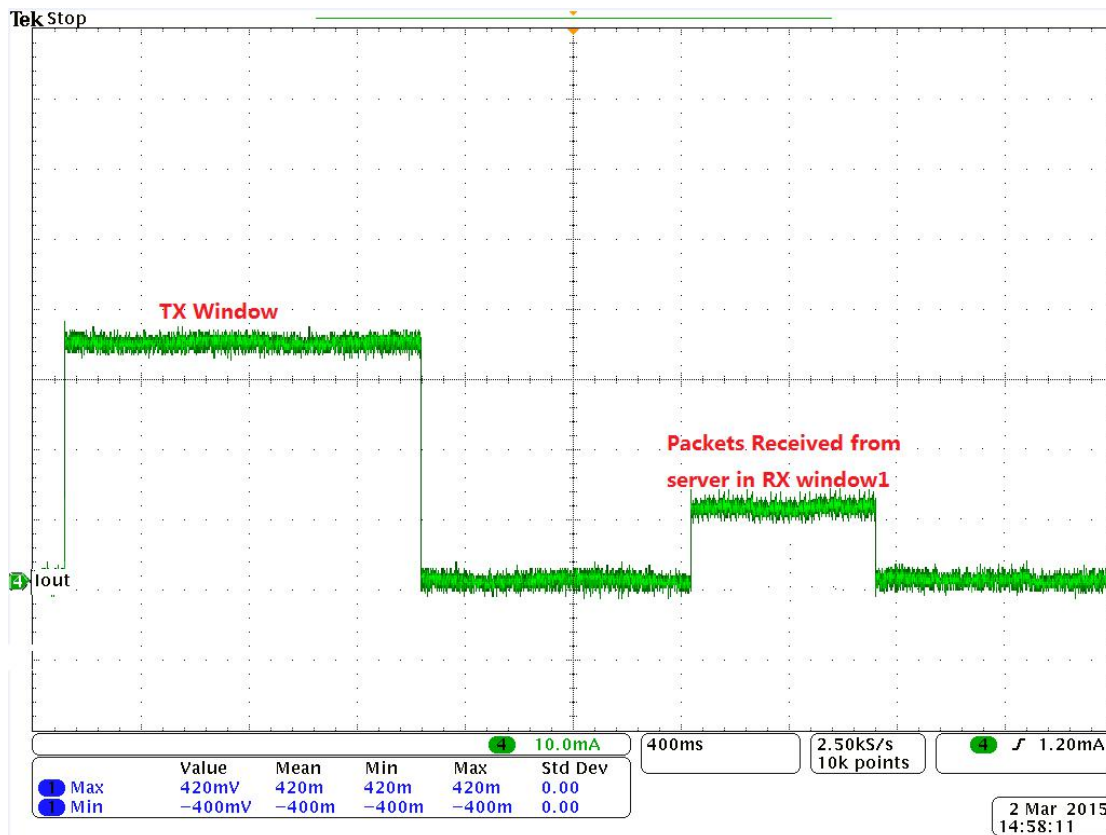

Figure 5- 1 Energy profile of RHF76-052 application in LoRaWAN (No packet received from Server)

In Figure 5-2, the node receive the packet from server in the RX window1.



**Figure 5-2 Energy profile of RHF76-052 application in LoRaWAN
(A packet received from Server in RX window1)**

Part II-AT Command Specifications

6 Introduction of AT Command

RisingHF™ LoRaWAN™ modem is [LoRaWAN](#) compatible device, which supports flexible LoRaWAN communication. This document is intended to describe a command interface implementation of LoRaWAN Class A/C protocol. LoRaWAN protocol is available from LoRa Alliance, it is recommended to review LoRaWAN specification before using LoRaWAN modem.

6.1 Feature

- Maximum 255 bytes frame
- User configuration nonvolatile
- Support all LoRaWAN R1.0 data rate schemes(EU868/US915/EU868-like)
- Customized data rate scheme
- LoRaWAN Class A/C
- Numerous test commands (LoRa P2P, Class C downlink, Continuous Wave etc.)
- Flexible hexadecimal string parser
- Ultra-low power (1.4uA@3.3V)¹
- Case insensitive commands
- Flexible RXWIN2 configuration interface
- Configurable RXWIN1 channel frequency
- Possibility to enable full-duplex LoRaWAN system

6.2 Related Products

Part Number	Bootloader	Interface
RHF3M076	USB	USB
RHF76-052 AM	UART	UART
RHF76-052 AN	USB	UART

Table 4- 1 Related products list

Note: RHF76-052 AM and RHF76-052 AN is based on the same hardware, which is that only the firmware upgrade is different

¹ UART interface modem only

7 Essential informations before using AT command

7.1 Conventions

- Command is case insensitive;
- All commands have response;
- Command length never exceeds total 528 characters;
- One valid AT Command must end with '\n', "\r\n" is also valid;
- If command timeout feature is enabled, end '\n' will not be mandatory;
- <LF> means the newline character. <CR> means carriage return;
- UART² configuration "9600, 8, n 1" (8 bits data, no parity, 1 stop bit);

7.2 Symbols

- = --> Set value for command
- ? --> Query
- : --> Start a list input parameter
- + --> Prefix of command
- , --> Separator of parameters
- Space --> Empty character, could be used to format command

NOTE: You could use quote sign <"> to force input parameter with space, such as <AT+MSGHEX="AA BB CC DD EE">, then "AA BB CC DD EE" is treated as one parameter. But if you input command <AT+MSGHEX=AA BB CC DD EE>, "AA BB CC DD EE" will treated as 5 parameters, AT+MSGHEX returns error.

7.3 Format

All commands in this document are end with <CR><LF>. In order to facilitate the description, all <CR><LF> is intentionally omitted in this document.

7.3.1 Query

Use query command to check LoRaWAN modem configuration, such as channel configuration, ADR status, TX power, etc.

```
AT+COMMAND
AT+COMMAND?
AT+COMMAND=?
```

NOTE: Query format is available with every LoRaWAN supported command

7.3.2 Configure / Control

Uses configure/control command to set new configuration or control transaction.

```
AT+COMMAND=DATA
```

7.3.3 Return

Return data is in format like "+CMD: RETURN DATA"

```
+COMMAND: "RETURN DATA"
```

² **RHF76-052AM** supports UART interface

RHF3M076 supports USB CDC interface of which UART configuration is unconcerned

7.4 Error

Code	Comment
-1	The number of parameters is invalid
-2	The content of the parameter is invalid
-3	API function returns error when user parameter is passed to it
-4	LoRaWAN modem can't save parameter to EEPROM
-5	The command is disabled currently
-6	Unknown error occurs
-7	There is not enough HEAP to execute user operation
-10	Command unknown
-11	Command is in wrong format
-12	Command is unavailable in current mode (Check with "AT+MODE")
-20	Too many parameters. LoRaWAN modem support max 15 parameters
-21	Length of command is too long (exceed 528 bytes)
-22	Receive end symbol timeout, command must end with <LF>
-23	Invalid character received

Table 5-1 Error code list

This error code list applies to all LoRaWAN supported command. User could refer to this list to know what is happening to LoRaWAN modem, when gets errors.

7.5 EEPROM

Items below will be synchronized to EEPROM of LoRaWAN modem once changed successfully, this makes LoRaWAN mode memorized, user doesn't need to reconfigure parameter after repower, LoRaWAN modem helps to keep it. If user wants to go back factory default configuration, refer to 3.18 FDEFAULT.

Item
Channel frequency, datarate range (up to 16 channels)
Datarate
TX power
ADR
RX Window2 frequency/datarate
RX Window1 frequency
Keys(NwkSkey, AppSkey, AppKey)
ID(DevAddr, DevEUI, AppEui)
PORT
Unconfirmed message repetition
Mode ³
LWABP/LWOTAA
Customize data rate scheme
Delay(RX1, RX2, JRX1, JRX2)

Table 5-2 Memorized configuration

³ Test mode is not stored; a reset during test mode makes modem switch back to previous mode.

7.6 Payload Length Limitation

Payload length depends on the current using spread factor and band width. Table below shows the relationship of “Spread Factor”, “Band Width”, “PHYPayload” and “MacPayload”.

Spread Factor	Band Width	PHYPayload	MacPayload	FRMPayload
----------------------	-------------------	-------------------	-------------------	-------------------

8 AT Commands description

Command	Description
AT	Test command
HELP	Print command list
FDEFAULT	Factory data reset
RESET	Software reset
DFU	Force bootloader to enter dfu mode
LOWPOWER	Enter sleep mode
VER	Version[Major.Minor.Patch]
MSG	LoRaWAN unconfirmed data
MSGHEX	LoRaWAN unconfirmed data in hex
CMSG	LoRaWAN confirmed data
CMSGHEX	LoRaWAN confirmed data in hex
CH	LoRaWAN channel frequency
DR	LoRaWAN datarate
ADR	LoRaWAN ADR control
REPT	Unconfirmed message repetition
POWER	LoRaWAN TX power
RXWIN2	LoRaWAN RX window2
RXWIN1	Customized RXWIN1 frequency
PORT	LoRaWAN communication port
MODE	LWABP, LWOTAA, TEST
ID	LoRaWAN DevAddr/DevEui/AppEui
KEY	Set NWKSKEY/APPSKEY/APPKEY
CLASS	Choose LoRaWAN modem class(A/B/C)
JOIN	LoRaWAN OTAA JOIN
TEST	Send test serious command
UART	UART configure
DELAY	RX window delay

Table 6- 1 Command List

8.1 AT

Use to test if connection of module is OK. This is a dummy command just like other common "AT modules"

Format:

```
AT
AT?
```

Return:

```
+AT: OK
```

8.2 ID

Use to check the ID of the LoRaWAN module, or change the ID.

Read ID Format:

```
AT+ID // Read all, DevAddr(ABP), DevEui(OTAA), AppEui(OTAA)
AT+ID? // Read all
AT+ID=? // Read all
AT+ID=DevAddr // Read DevAddr
AT+ID=DevEui // Read DevEui
AT+ID=AppEui // Read AppEui
AT+ID=DevAddr, "new devaddr" // Set new DevAddr
AT+ID=DevEui, "new deveui" // Set new DevEui
AT+ID=AppEui, "new appeui" // Set new AppEui
```

Return:

```
+ID: DevAddr, xx:xx:xx:xx
+ID: DevEui4, xx:xx:xx:xx:xx:xx:xx:xx
+ID: AppEui5, xx:xx:xx:xx:xx:xx:xx:xx
```

Change end device address (**DEVADDR**)

```
AT+ID=DevAddr, "4 bytes length hex identifier"
eg: AT+ID=DevAddr, "01234567"
eg: AT+ID=DEVADDR, "01 23 45 67"
```

Return:

```
+ID: DevAddr, 01:23:45:67
```

Change device extended unique identifier (**DEVEUI**)

```
AT+ID= DevEui, "8 bytes length hex identifier (64bit)"
eg: AT+ID=DevEui, "0123456789ABCDEF"
eg: AT+ID=DEVEUI, "01 23 45 67 89 AB CD EF"
```

Return:

```
+ID: DevEui, 01:23:45:67:89:AB:CD:EF
```

Change device extended unique identifier (**APPEUI**)

⁴ DevEui which is supplied by RisingHF are derived from STM32's UUID, these EUIs are RisingHF unique is not standard IEEE EUI-64, , it is recommended to apply and use IEEE-EUI64.

⁵ Default AppEui is **52:69:73:69:6E:67:48:46**

AT+ID= AppEui, "8 bytes length hex identifier (64bit)"

eg: AT+ID=AppEui, "0123456789ABCDEF"

eg: AT+ID=APPEUI, "01 23 45 67 89 AB CD EF"

Return:

+ID: AppEui, 01:23:45:67:89:AB:CD:EF

8.3 RESET

Use to reset the module. If module returns error, then reset function is invalid.

Format:

AT+RESET

Return:

+RESET: OK

+RESET: ERROR(-5) // USB interface device returns error

Note: This command is unavailable if the LoRaWAN modem is USB interface device

8.4 MSG

Use to send string format frame which is no need to be confirmed by the server.

Format:

AT+MSG="Data to send"

Return:

+MSG: Start LoRaWAN transaction

+MSG: TX "xxxxxx"

+MSG: Done

Example: (Normal)

+MSG: Start LoRaWAN transaction

+MSG: TX "RisingHF"

+MSG: Done

Example: (Downlink message, RX payload is in hex format)

+MSG: Start LoRaWAN transaction

+MSG: TX "RisingHF"

+MSG: PORT: 8; RX: "12 34 56 78"

+MSG: RXWIN2⁶, RSSI -106, SNR 4

+MSG: Done

Example: (MAC command received)

+MSG: Start LoRaWAN transaction

+MSG: TX "RisingHF"

+MSG: LoRaWAN command received

+MSG: RXWIN2, RSSI -88, SNR 13.75

+MSG: Done

8.5 CMSG

Use to send string format frame which must be confirmed by the server.

Format:

⁶ RXWIN2: Message is received during RX Window2; RXWIN1: RX Window1; RXWIN0: Class C Extra RXWIN2.

AT+CMMSG="Data to send"

Return: (NACK)

+CMMSG: Start LoRaWAN transaction
+CMMSG: TX "RisingHF"
+CMMSG: Wait ACK
+CMMSG: Done

Return: (ACK Received)

+CMMSG: Start LoRaWAN transaction
+CMMSG: TX "RisingHF"
+CMMSG: Wait ACK
+CMMSG: ACK Received
+CMMSG: RXWIN2, RSSI -88, SNR 13.75
+CMMSG: Done

Return: (ACK with Payload received)

+CMMSG: Start LoRaWAN transaction
+CMMSG: Wait ACK
+CMMSG: ACK Received
+CMMSG: PORT: 5; RX: "14 54 54"
+CMMSG: RXWIN2, RSSI -88, SNR 13.5
+CMMSG: Done

8.6 MSGHEX

Use to send hex format frame which is no need to be confirmed by the server.

Format:

AT+MSGHEX="xx xx xx xx"
eg: AT+MSGHEX="11 22 33 AA BB FF"

Return:

+MSGHEX: Start LoRaWAN transaction
+MSGHEX: TX "xxxxxx"
+MSGHEX: Done

For detailed examples, please refer to MSG. MSG and MSGHEX are the same command except payload format.

8.7 CMSGHEX

Use to send hex format frame which must be confirmed by the server.

Format:

AT+CMSGHEX="Data to send"
eg: AT+CMSGHEX="11 22 33 AA BB FF"

Return:

+CMSGHEX: Start LoRaWAN transaction
+CMSGHEX: TX "xxxxxx"
+CMSGHEX: Wait ACK
+CMSGHEX: Done

For detailed examples, please refer to CMSG. CMSG and CMSGHEX are the same command except payload format.

8.8 PORT

Set PORT number which will be used by MSG/CMSG/MSGHEX/CMSGHEX command to send message, port number should range from 1 to 255. User should refer to LoRaWAN specification to choose port.

Format:

```
AT+PORT="port"           // "port" should be 1~255
eg: AT+PORT=8           // Set port to 8
eg: AT+PORT=?           // Check current port
```

Return:

```
+PORT: 8                // PORT query/set return
```

8.9 ADR

Set ADR function of LoRaWAN module.

Format:

```
AT+ADR="New state"
eg: AT+ADR=ON           // Enable ADR function
AT+ADR=OFF             // Disable ADR function
AT+ADR=?               // Check current ADR configuration
```

Return:

```
+ADR: ON                // ADR query/set return
```

8.10 DR

Use LoRaWAN defined DRx to set datarate of LoRaWAN AT modem. Refer to Table 3-2 LoRaWAN EU868 Data Rate Scheme and Table 3-3 LoRaWAN US915 Data Rate Scheme about the detailed definition of LoRaWAN data rate.

Format:

```
AT+DR="DRx"            // "DRx" should range 0~15
eg: AT+DR=0
eg: AT+DR=5
eg: AT+DR=DR0
eg: AT+DR=DR5
eg: AT+DR=?           // Check current selected DataRate
```

Return:

```
+DR: DR0
+DR: US915 DR0 SF10 BW125K
```

Return: (ADR is functional)

```
+DR: DR0 (ADR DR3)
+DR: US915 DR3 SF7 BW125K
+DR: US915 DR0 SF10 BW125K
```

8.10.1 Datarate Scheme

LoRaWAN R1.0 defines 2 kinds of datarate scheme: EU868 (or EU868-like) and US915. RisingHF LoRaWAN modem supports both this 2 kinds of datarate.

Check data rate scheme:

```
AT+DR=SCHEME // Check current band
```

Return: (US915)

```
+DR: US915
+DR: US915 DR0 SF10 BW125K
+DR: US915 DR1 SF9 BW125K
+DR: US915 DR2 SF8 BW125K
+DR: US915 DR3 SF7 BW125K
+DR: US915 DR4 SF8 BW500K
+DR: US915 DR5 RFU
+DR: US915 DR6 RFU
+DR: US915 DR7 RFU
+DR: US915 DR8 SF12 BW500K
+DR: US915 DR9 SF11 BW500K
+DR: US915 DR10 SF10 BW500K
+DR: US915 DR11 SF9 BW500K
+DR: US915 DR12 SF8 BW500K
+DR: US915 DR13 SF7 BW500K
+DR: US915 DR14 RFU
+DR: US915 DR15 RFU
```

Return: (EU868)

```
+DR: EU868
+DR: EU868 DR0 SF12 BW125K
+DR: EU868 DR1 SF11 BW125K
+DR: EU868 DR2 SF10 BW125K
+DR: EU868 DR3 SF9 BW125K
+DR: EU868 DR4 SF8 BW125K
+DR: EU868 DR5 SF7 BW125K
+DR: EU868 DR6 SF7 BW250K
+DR: EU868 DR7 FSK 50kbps
+DR: EU868 DR8 RFU
+DR: EU868 DR9 RFU
+DR: EU868 DR10 RFU
+DR: EU868 DR11 RFU
+DR: EU868 DR12 RFU
+DR: EU868 DR13 RFU
+DR: EU868 DR14 RFU
+DR: EU868 DR15 RFU
```

Return: (CUSTOM)

```
+DR: CUSTOM
+DR: CUSTOM DR0 RFU
+DR: CUSTOM DR1 RFU
+DR: CUSTOM DR2 RFU
+DR: CUSTOM DR3 RFU
```



```
+DR: CUSTOM DR4 RFU
+DR: CUSTOM DR5 RFU
+DR: CUSTOM DR6 RFU
+DR: CUSTOM DR7 RFU
+DR: CUSTOM DR8 RFU
+DR: CUSTOM DR9 RFU
+DR: CUSTOM DR10 RFU
+DR: CUSTOM DR11 RFU
+DR: CUSTOM DR12 RFU
+DR: CUSTOM DR13 RFU
+DR: CUSTOM DR14 RFU
+DR: CUSTOM DR15 RFU
```

Choose data rate scheme

```
AT+DR=EU868 // LoRaWAN EU868 data rate scheme
AT+DR=US915 // LoRaWAN US915 data rate scheme
AT+DR=CUSTOM // Customized data rate scheme
```

LoRaWAN Data Rate	Configuration	Indicative physical bit rate [bit/s]
DR0	LoRa SF12/125KHz	250
DR1	LoRa SF11/125KHz	440
DR2	LoRa SF10/125KHz	980
DR3	LoRa SF9/125KHz	1760
DR4	LoRa SF8/125KHz	3125
DR5	LoRa SF7/125KHz	5470
DR6	LoRa SF7/250KHz	11000
DR7	FSK:50kbps	50000
DR8-DR15	RFU	RFU

Table 6-2 LoRaWAN EU868 Data Rate Scheme

LoRaWAN Data Rate	Configuration	Indicative physical bit rate [bit/s]
DR0	LoRa SF10/125KHz	980
DR1	LoRa SF9/125KHz	1760
DR2	LoRa SF8/125KHz	3125
DR3	LoRa SF7/125KHz	5470
DR4	LoRa SF8/500KHz	12500
DR5-DR7	RFU	RFU
DR8	LoRa SF12/500KHz	980
DR9	LoRa SF11/500KHz	1760
DR10	LoRa SF10/500KHz	3900
DR11	LoRa SF9/500KHz	7000
DR12	LoRa SF8/500KHz	12500
DR13	LoRa SF7/500KHz	21900
DR14-DR15	RFU	RFU

Table 6-3 LoRaWAN US915 Data Rate Scheme

8.10.2 Customized Data Rate Scheme

In order to provide maximum flexibility to define data rate, this customized data rate scheme feature is added from firmware v1.8.0.

Define a new data rate:

```
AT+DR=CUSTOM, DRx, SFx, BW, [DRx (RXWin1)]
```

Note: [DRx (RXWin1)] is optional parameter, which could be used to specify an RXWin1 data rate for a predefined data rate. For example, "AT+DR=CUSTOM, DR0, SF10, 500, DR4" will map DR0 and DR4, this means when sending a message use DR0, RXWIN1 will set DR11 to receive downlink. This feature is useful when downlink output power is higher than uplink, in this situation, it is reasonable to use higher data rate and still keep uplink budget and downlink budget balance, and make whole network high efficient. If absent, RXWIN1 data rate will be set to the same as uplink data rate in default.

Set data rate to RFU (Reserve For Use)

```
AT+DR=CUSTOM, DRx, RFU
```

Example:

```
// Set DR0 to SF7 and BW125KHz
AT+DR=CUSTOM, DR0, SF7, 125
```

Return:

```
+DR: CUSTOM DR0 SF7 BW125K //By default downlink DR is the same as uplink DR
```

Example:

```
// Set DR0 to SF9 and BW500KHz, and map DR0 (uplink) with DR11 (downlink).
AT+DR=CUSTOM, DR3, SF10, 500, DR4
```

Return:

```
+DR: CUSTOM DR3 SF10 BW500K DLDR4
```

Example:

```
// Set DR0 to FSK 50kpbs
AT+DR=CUSTOM,DR0,FSK
```

Return:

```
+DR: CUSTOM DR0 FSK 50kpbs
```

Example:

```
// Set DR0 to FSK 50kpbs, and map DR0 with DR5,
// Note: [BW] parameter should be set to 0 or any other integer.
AT+DR=CUSTOM,DR0,FSK,0,DR5
```

Return:

```
+DR: CUSTOM DR0 FSK 50kpbs
```

Example:

```
// Set DR0 to RFU
AT+DR=CUSTOM, DR0, RFU
```

Return:

```
+DR: CUSTOM DR0 RFU
```

Example:

```
// Check custom data rate scheme
AT+DR=CUSTOM
AT+DR=SCHEME
```

Return:

```
+DR: CUSTOM
+DR: CUSTOM DR0 SF7 BW125K
+DR: CUSTOM DR1 RFU
+DR: CUSTOM DR2 RFU
+DR: CUSTOM DR3 SF10 BW500K DLDR4
+DR: CUSTOM DR4 RFU
+DR: CUSTOM DR5 RFU
+DR: CUSTOM DR6 RFU
+DR: CUSTOM DR7 RFU
+DR: CUSTOM DR8 RFU
+DR: CUSTOM DR9 RFU
+DR: CUSTOM DR10 RFU
+DR: CUSTOM DR11 RFU
+DR: CUSTOM DR12 RFU
+DR: CUSTOM DR13 RFU
+DR: CUSTOM DR14 RFU
+DR: CUSTOM DR15 RFU
```

Note: After changing the data rate scheme, user should run commands below to check if the data rate settings are valid, and make sure no RFU data rate is used.

```
AT+CH
AT+RXWIN2
AT+DR
```

8.11 CH

Set channel parameter of LoRaWAN modem, Set frequency zero to disable one channel.

Format:

```
AT+CH="LCn", ["Freq"], ["DR_MIN"], ["DR_MAX"]
// Change the LCn channel frequency to "Freq"
// "Freq" is in MHz.
// Available DR_MIN/DR_MAX range DR0 ~ DR15
```

1. Change channel LC0 frequency to 433.3MHz, datarate DR0~DR5
eg: AT+CH=0, 433.3, DR0, DR5
2. Change channel LC1 frequency to 433.5MHz, datarate DR0~DR2
eg: AT+CH=1, 433.5, DR0, DR2

3. Disable channel LC2
eg: AT+CH=2, 0
4. Change channel LC3 frequency to 433.7MHz, with default datarate DR0~DR5
eg: AT+CH=?
eg: AT+CH=3, 433.7
// It is not recommended to use this command
5. Change channel LC0 frequency to 433.3MHz,DR7
eg: AT+CH=0, 433.3, DR7
6. Change channel LC3 frequency to 433.7MHz, datarate DR0~DR5
eg: AT+CH=3, 433.7, 0, 5
7. Change channel LC3 frequency to 433.7MHz, datarate DR7
eg: AT+CH=3, 433.7, DR7

Return:

```
+CH: 3,433700000,DR0:DR5
+CH: 3,433700000,DR1
```

Query Return Format:

```
+CH: TOTAL_CHANNEL_NUMBER; LCn,FREQn,DR_MINn,DR_MAXn; LCy,FREQy,DR_MINy,DR_MAXy; ...
LCz,FREQz,DR_MINz,DR_MAXz;
eg: +CH: 8; 0,433300000,DR0,DR5; 1,433500000,DR0,DR5; 2,433700000,DR0,DR5;
3,433900000,DR0,DR5; 4,434100000,DR0,DR5; 5,434300000,DR0,DR5; 6,434500000,DR0,DR5;
7,434700000,DR0,DR5;
```

8.12 POWER

Set TX power of LoRaWAN AT Module, valid power value 20, 14, 11, 8, 5, 2.

Format:

```
AT+POWER="Power value" // Change LoRaWAN Tx Power
eg: AT+POWER=14 // Change LoRaWAN AT module TX power to 14dBm
```

Return:

```
+POWER: 14
```

8.13 REPT

Unconfirmed message repeats times.

Format:

```
AT+REPT="Repeat Times" //Repeat times" should range 1~15
eg: AT+REPT=2 //Repeat 2 times
```

Return:

```
+REPT: 2
```

8.14 RXWIN2

Set second RX window frequency and Data Rate. This command will change RXWIN2 configuration, which may cause downlink lost, if configuration is wrong.

Format:

```
AT+RXWIN2=Frequency,DRx           // Set frequency and datarate
AT+RXWIN2=Frequency,SFx,BW         // Set RXWIN2 through SF and BW
AT+ RXWIN2=?                       // Query RX Window2 configuration
AT+ RXWIN2?                         // Query RX Window2 configuration
AT+ RXWIN2                          // Query RX Window2 configuration
eg: AT+RXWIN2=433.3,DR3            // Set RXWIN2 433.3MHz/DR3
eg: AT+RXWIN2=433.3,SF7,500       // Set RXWIN2 433.3MHz/SF7/BW500KHz
```

Return:

```
// General data rate
+RXWIN2: 433300000,DR5
// Customized RX Window2 data rate with spread factor and band width
+RXWIN2: 433000000,SF7,BW125K
```

From firmware 1.8.0, RXWIN2 command could support more flexible configuration. Both LoRaWAN defined data rate (combination of spread fraction and band width) and LoRa defined spread factor and band width format are supported. User could set his RXWIN2 to any possible SF and BW scheme, which is a very useful function for LoRaWAN proof of concept.

8.15 RXWIN1

RXWIN1 command could be used to set customized RXWIN channel, each RXWIN channel maps to an uplink channel. When RXWIN1 is enabled, user need make sure every uplink channel has its own mapped RXWIN1 channel, or the modem may perform unexpected.

With this special RXWIN1 command, a function of frequency shift between uplink and downlink is possible, then full-duplex is easy to achieve for the system if gateway support.

a) Enable RXWIN1

```
AT+RXWIN1=ON
```

b) Disable RXWIN1

```
AT+RXWIN1=OFF
```

c) Set RXWIN1

```
AT+RXWIN1=CH,FREQ
```

CH is the channel number 0~16. FREQ is in MHz

```
eg: AT+RXWIN1=0,868.9
```

d) Check RXWIN1

```
AT+RXWIN1           // return normal or special case
// RXWIN1 is disabled
+RXWIN1: OFF
// RXWIN1 is enabled
+RXWIN1: ON; 8; 0, 923300000; 1, 923900000; 2, 924500000; 3, 925100000;
4, 925700000; 5, 926300000; 6, 926900000; 7, 927500000;
```

8.16 VER

Check firmware version. Versioning rule refers to [Semantic Versioning 2.0.0](#).

Format:

```
AT+VER=?  
AT+VER?  
AT+VER
```

Return:

```
+VER: $MAJOR.$MINOR.$PATCH  
+VER: 1.8.0
```

8.17 KEY

Change LoRaWAN related AES-128 KEY. If wrong key is used, your LoRaWAN modem will be rejected by LoRaWAN server. Contact server administrator to know what key should use. All KEYS are unreadable for security, the one who forgets his KEY need rewrite with a new key.

Format:

Change network session key (NWKSKEY)

```
AT+KEY=NWKSKEY, "16 bytes length key"  
eg: AT+KEY=NWKSKEY, "2B7E151628AED2A6ABF7158809CF4F3C"  
eg: AT+KEY=NWKSKEY, "2B 7E 15 16 28 AE D2 A6 AB F7 15 88 09 CF 4F 3C"
```

Return:

```
+KEY: NWKSKEY 2B 7E 15 16 28 AE D2 A6 AB F7 15 88 09 CF 4F 3C
```

Change application session key (APPSKEY)

```
AT+KEY=APPSKEY, "16 bytes length key"  
eg: AT+KEY=APPSKEY, "2B7E151628AED2A6ABF7158809CF4F3C"  
eg: AT+KEY=APPSKEY, "2B 7E 15 16 28 AE D2 A6 AB F7 15 88 09 CF 4F 3C"
```

Return:

```
+KEY: APPSKEY 2B 7E 15 16 28 AE D2 A6 AB F7 15 88 09 CF 4F 3C
```

Change application session key (APPKEY)

```
AT+KEY=APPKEY, "16 bytes length key"  
eg: AT+KEY=APPKEY, "2B7E151628AED2A6ABF7158809CF4F3C"  
AT+KEY=APPKEY, "2B 7E 15 16 28 AE D2 A6 AB F7 15 88 09 CF 4F 3C"
```

Return:

```
+KEY: APPKEY 2B 7E 15 16 28 AE D2 A6 AB F7 15 88 09 CF 4F 3C
```

8.18 FDEFAULT

Reset LoRaWAN AT modem to factory default configuration. Command "AT+FDEFAULT=RISINGHF" should be used to do the factory reset. Company name "RISINGHF" (case insensitive) is kept on purpose to avoid command to be triggered unexpectedly. After reset user could use "Query" format command to know which configuration is used.

Format:

AT+FDEFAULT=RISINGHF

Return:

+FDEFAULT: OK

Item	Value
Channel	3 channels CH0: 868.1MHz CH1: 868.3MHz CH2: 868.5MHz
Datarate Range	DR0 : DR5
Unconfirmed Message Repetition	1
Confirmed Message Retry⁷	3
Port	8
Datarate	DR0
ADR	ON
Power	14dBm
RXWIN2	869.525MHz, DR3
RXWIN1 Delay	1s
RXWIN2 Delay	2s
JOIN ACCEPT RXWIN1 Delay	5s
JOIN ACCEPT RXWIN2 Delay	6s

Table 6-4 Factory default configuration

NOTE: Customized modem may be precompiled to use a different factory default configuration. If any user has request, please contact RisingHF support@risinghf.com.

8.19 DFU

Use to enter DFU mode. If user need to enter DFU mode to update LoRaWAN modem firmware, then user should first send "AT+DFU=ON" command to enable firmware upgrade. Once DFU mode is on, user should repower LoRaWAN modem (unplug and plug back), after repowered LoRaWAN will enter DFU mode, user could use DfuSe tool to update the firmware. If user want to exit DFU mode without upgrade, user just need to repower again, LoRaWAN modem will exit DFU mode automatically.

For UART bootloader, "AT+DFU=ON" command will make device enter bootloader mode automatically.

Format:

```
AT+DFU="New state"
eg: AT+DFU=ON           // Enable DFU function
eg: AT+DFU=OFF         // Disable DFU function
AT+DFU=?               // Check if DFU is enabled configuration
```

Return:

```
+DFU: ON
+DFU: OFF
```

Example: (RHF76-052AM/RHF76-052AN)

```
+DFU: ON
Enter bootloader mode after reboot
```

⁷ Confirmed message retry number of time is fixed value, which can't be change through AT command.

Reboot in 5s...

Example: (RHF3M076)

```
+DFU: ON // Need manually repower RHF3M076 device
```

Note: DFU mode is risky. Before updating, user must make sure the firmware is supplied by RisingHF, a wrong firmware may brick LoRaWAN modem.

8.20 HELP

Return brief help information. Refer to Table 3-1 Command List.

Format:

```
AT+HELP=?
```

```
AT+HELP?
```

```
AT+HELP
```

Return:

```
+HELP: OK
```

```
AT -- AT Ping
```

```
HELP -- Print command list
```

```
FDEFAULT -- Factory data reset
```

```
RESET -- Software reset
```

```
DFU -- Bootloader mode
```

```
LOWPOWER -- Enter sleep mode
```

```
VER -- Version
```

```
MSG -- Unconfirmed
```

```
MSGHEX -- Unconfirmed (HEX)
```

```
CMSG -- Confirmed
```

```
CMSGHEX -- Confirmed (HEX)
```

```
CH -- Set channel
```

```
ADR -- ADR ON/OFF
```

```
DR -- Set datarate
```

```
REPT -- MSG/MSGHEX repetition
```

```
POWER -- TX power
```

```
RXWIN1 -- RX window1
```

```
RXWIN2 -- RX window2
```

```
PORT -- TX port
```

```
MODE -- LWABP/LWOTAA/TEST
```

```
ID -- DevAddr/DevEui/AppEui
```

```
KEY -- NWKSKEY/APPSKEY/APPKEY
```

```
CLASS -- Class(A/B/C)
```

```
JOIN -- OTAA Join request
```

```
TEST -- Test commands
```

```
UART -- UART configure
```

```
DELAY -- RX window delay
```

8.21 MODE

Use to select work mode. LWABP⁸, LWOTAA⁹, TEST are supported. LoRaWAN modem can only work with one mode at a time. By default, LWABP is enabled, all test commands are unavailable, LoRaWAN will return error(-12) if it receives test command in non-test mode.

"AT+MODE" command will reset LoRaWAN stack when first enter LWABP/LWOTAA mode and reset LoRa chip when first enter test mode.

LWABP/LWOTAA mode status is remembered by LoRaWAN modem, each time LoRaWAN modem starts, it will enter previous working mode before reset or repower.

Format:

```
AT+MODE="New mode"
eg: AT+MODE=TEST           // Enter TEST mode
eg: AT+MODE=LWOTAA         // Enter TEST mode
eg: AT+MODE=LWABP         // Enter LWABP mode
```

Return

```
+MODE: LWABP           // Enter LWABP mode successfully
+MODE: LWOTAA          // Enter LWABP mode successfully
+MODE: TEST            // Enter TEST mode successfully
```

8.22 JOIN

When OTAA mode is enabled, JOIN command could use to join a known network.

Format:

```
AT+JOIN=["Times"], ["DELAY"], ["DELAY RANDOM OFFSET"]
AT+JOIN=REJOIN
```

1. Query

```
eg: AT+JOIN=?           // Query JOIN status
eg: AT+JOIN?           // Query JOIN status
```

2. Join

```
eg: AT+JOIN             // Send JOIN request
```

3. Disconnect with current network, force send one JOIN request

```
eg: AT+JOIN=FORCE
```

4. Stop JOIN

```
eg: AT+JOIN=STOP
```

5. Auto send JOIN request 10 times with (20 +/- 4)s delay, set times to 0 join forever.

```
eg: AT+JOIN=10, 20, 4
eg: AT+JOIN=0           // JOIN forever with default delay(10 +/- 2)s
```

⁸ LWABP is short for **LoRaWAN Activation By Personalization**. Check < LoRaWAN™ Specification > for details

⁹ LWOTAA is short for **LoRaWAN Over-The-Air-Activation**.

6. Returns

- a) Join successfully
 - +JOIN: Starting
 - +JOIN: NORMAL, count 1, 0s, 0s
 - AT+DR=CUSTOM,DR0,FSK
 - +JOIN: NetID 000024 DevAddr 48:00:00:01
 - +JOIN: Done
- b) Join failed
 - +JOIN: Join failed

8.23 CLASS

This command could enable LoRaWAN modem to work at different mode (Class A/B¹⁰/C). LoRaWAN modem works at class A mode when power on, user need manually switch mode to class B/C as needed.

Format:

```
eg: AT+CLASS=A           // Enable Class A mode
eg: AT+CLASS=C           // Enable Class C mode
```

Return

```
+CLASS: A                // Enter LWABP mode successfully
```

8.24 LOWPOWER¹¹

Sleep command could be used to make modem enter sleep mode with ultra-low power consumption, check device datasheet to know detailed parameters. After device enters in sleep mode, host device could send any character to wakeup it, after wakeup host should wait at least 5ms to send next commands, a C code example is attached to show how to handle LOWPOWER mode.

During the LOWPOWER mode, level of UART RX pin must keep unchanged, any signal on UART RX pin will make modem exit LOWPOWER mode. When LOWPOWER mode is triggered, there are extra 30ms before modem really enter sleep mode, host device should use this time to de-initial its UART if it is needed.

Format:

```
eg: AT+LOWPOWER           // Sleep command supports only this format
                          // Query symbol is not available
```

Return

```
+ LOWPOWER: SLEEP         // Enter SLEEP mode successfully
+ LOWPOWER: WAKEUP        // Modem is woke up.
```

C example:

```
printf("AT+LOWPOWER\r\n");// Set low-power mode
// ...
// HOST do other operation.
// ...
printf("A");               // Send any character to wake-up the modem
DelayMs(5);                // Wait modem ready
printf("AT+ID\r\n");       // New operation
```

¹⁰ Class B is unavailable in current version

¹¹ RHF76-052AM (UART enabled) supports this feature, RHF3M076 (USB enabled) doesn't support sleep mode.

8.25 TEST

TEST command is not like other command, it is a serious command, includes several sub-commands, refer to table below. With test mode, user could do RF performance test quickly without any knowledge of LoRa chip. Commands which are related to RF configuration is disabled in test mode.

Sub-Command	Comment
HELP	Print test command help information, make LoRa transceiver to standby mode
STOP	Set LoRaWAN Modem to TEST stop mode
TXCW	Transmit continuous wave
TXCLORA	Transmit continuous LoRa signal
RFCFG	Set RF configuration in TEST mode
RXLRPKT	Continuous receive pure LoRa packet, print once there is new packet received
TXLRPKT	Send one HEX format packet out
TXLRSTR	Send one string format packet
RSSI	Get RSSI value of specified channel
LWDL	Send LoRaWAN downlink packet, useful tool to test CLASS C device

Table 6-5 TEST mode sub-command list

8.25.1 Print Help Information

Format:

`AT+TSET=HELP`

Return:

```
+TEST: HELP
      STOP -- AT+TEST=STOP
      HELP -- AT+TSET=HELP
      TXCW -- AT+TEST=TXCW
      TXCLORA -- AT+TEST=TXCLORA
      RFCFG -- AT+TEST=RFCFG, [F], [SF], [BW], [TXPR], [RXPR], [POW]
      RXLRPKT -- AT+TEST=RXLRPKT
      TXLRPKT -- AT+TEST=TXLRPKT, "HEX"
      TXLRSTR -- AT+TEST=TXLRSTR, "TEXT"
      RSSI -- AT+TEST=RSSI, F, [CNT]
      LWDL -- AT+TEST=LWDL, TYPE, DevAddr, "HEX", [FCNT], [FPORT], [FCTRL]
```

"[]" means the parameter is omissible together with parameters behind it

8.25.2 Enter TEST mode

Before use any TEST command, LoRaWAN should work in test mode, or error code -12 will be reported.

Command:

`AT+MODE=TEST`

Return:

```
+MODE: TEST // LoRaWAN modem enter TEST mode successfully
```

8.25.3 Query RF configuration

First thing after enter TEST mode should be check RF configuration.

Command:

AT+TEST=? // Query test mode and RF configuration

Return Error:

+TEST: ERROR(-12)

When come with ERROR(-12), user could try "AT+MODE=?" to check if LoRaWAN modem is in TEST mode, if not user should enter test mode first.

Return STOP:

+TEST: STOP

+TEST: RFCFG F:433300000, SF12, BW125K, TXPR:8, RXPR:8, POW:14dBm

Return TXLRPKT:

+TEST: TXLRPKT

+TEST: RFCFG F:433300000, SF12, BW125K, TXPR:8, RXPR:8, POW:14dBm

Return RXLRPKT:

+TEST: RXLRPKT

+TEST: RFCFG F:433300000, SF12, BW125K, TXPR:8, RXPR:8, POW:14dBm

Return TXCW:

+TEST: TXCW

+TEST: RFCFG F:433300000, SF12, BW125K, TXPR:8, RXPR:8, POW:14dBm

8.25.4 Set RF Configuration

RFCFG supports set frequency, SF, band width, TX preamble, RX preamble and TX power settings.

TX and RX shares all configuration except "preamble length", user could choose different preamble length. For LoRa communication, it is strongly recommended to set RX preamble length longer than TX's. Bandwidth only supports 125KHz / 250KHz / 500KHz.

Depend on Semtech SX1276 (PA_BOOST/RFO) and design solution of RisingHF module, MAX output power of different band LoRaWAN modem could be different. Check below table about the details.

Device	Bootloader	Interface	LF Band ¹²	HF Band ¹³
RHF3M076	USB	USB	20dBm	14dBm
RHF76-052AM	UART	UART	20dBm	14dBm
RHF76-052AN	USB	UART	20dBm	14dBm

Table 6-6 MAX output power of HF and LF band

RHF3M076 is part number of RisingHF LoRaWAN modem.

Format:

"[" means the parameter is omissible together with parameters after it

¹² LF Band: Frequency is less than 525MHz

¹³ HF Band: Frequency is larger than 525MHz

```
AT+TEST=RFCFG,[FREQUENCY],[SF],[BANDWIDTH],[TX PR],[RX PR],[TX POWER]
```

```
// TX Configuration/868MHz/SF9/BW125KHz/TXPREAMBEL 12/RXPREAMBEL 15/14dBm
```

```
eg: AT+TEST=RFCFG,866,SF12,125,12,15,14
```

Return:

```
+TEST: RFCFG F:866000000,SF12,BW125K,TXPR:12,RXPR:15,POW:14dBm
```

8.25.5 TX LoRa Packet

After enter test mode, user could send LoRa packet through "AT+TEST=TXLRPKT" sub-command.

The command format is like below:

```
AT+TEST=TXLRPKT, "HEX STRING"
```

Command sequence to send LoRa packet:

```
// Set test mode
AT+MODE=TEST
// Query test mode, check RF configuration
AT+TEST=?
// Set RF Configuration
AT+TEST=RFCFG,[FREQUENCY],[SF],[BANDWIDTH],[TX PR],[RX PR],[TX POWER]
// Send HEX format packet
AT+TEST=TXLRPKT, "HEX String"
eg:AT+TEST=TXLRPKT, "00 AA 11 BB 22 CC"
// Send TEXT format packet
AT+TEST=TXLRSTR, "TEXT"
eg:AT+TEST=TXLRSTR, "LoRaWAN Modem"
```

Return:

```
+TEST: TXLRPKT "00 11 22 33 44"
+TEST: TXLRSTR "LoRaWAN Modem"
+TEST: TX DONE
```

8.25.6 RX LoRa Packet

After enter test mode, user could enter LoRa packet continuous RX mode through RXLRPKT sub-command. Like below:

```
AT+TEST=RXLRPKT
```

Command sequence to receive LoRa packet:

```
// Set test mode
AT+MODE=TEST
// Query test mode, check RF configuration
AT+TEST=?
// Set RF Configuration
AT+TEST=RFCFG,[FREQUENCY],[SF],[BANDWIDTH],[TX PR],[RX PR],[TX POWER]
// Enter RX continuous mode
AT+TEST=RXLRPKT
```

Return:

```
+TEST: LEN:250, RSSI:-106, SNR:10
+TEST: RX 00 11 22 33 44
```

8.25.7 TX Continuous Wave

Before enable TXCW function, right frequency and TX power should be set. Format:

```
AT+TEST=TXCW
```

Return:

```
+TEST: TXCW
```

8.25.8 TX Continuous LoRa

Before enable TXCLORA function, right frequency and TX power should be set. Format:

```
AT+TEST= TXCLORA
```

Return:

```
+TEST: TXCLORA
```

8.25.9 RSSI

Read RSSI from a specified channel. Format:

```
AT+TEST = RSSI, frequency(MHz), [times]
```

Return:

```
+TEST: RSSI, frequency
+TEST: RSSI 0, RSSI0; 1, RSSI1; ... n, RSSIn;
...
+TEST: RSSI n+1, RSSI0; n+2, RSSI1; ..., ...
...
+TEST: RSSI, AVG average, MAX maximum, MIN minimum
```

8.25.10 LWDL

LWDL command is designed to test LoRaWAN modem CLASS C function. Use this command, user can easily send data to a working LoRaWAN Class C device.

```
AT+TEST = LWDL, TYPE, "DevAddr", "HEX STRING", [FCNT], [FPORT], [FCTRL]
```

Return:

```
AT+TEST=LWDL,MSG,"009291ad","14 54 54 88 08 93 122 35", 1, 5, 00
+TEST: LWDL "A0 AD 91 92 00 00 01 00 05 13 4D 37 EA 53 E3 02 3A 9F 01 25 D2 34"
+TEST: LORAWAN DOWNLINK TX DONE
```

8.26 UART

8.26.1 TIMEOUT

LoRaWAN AT modem supports UART receive timeout feature, AT parser inside the modem start counts from first "AT" character is received, when counter overflows, a "Input timeout" event will be triggered. One message like below will be showed. Maximum timeout value is 300ms.

```
+INFO: Input timeout, start parse
```

```

AT+UART=TIMEOUT, 0           // Disable timeout feature
AT+UART=TIMEOUT, 1000        // Set timeout 1s feature
AT+UART=TIMEOUT              // Get timeout value
    
```

8.27 DELAY

RX window delay configuration command. Supports configure RECEIVE_DELAY1, RECEIVE_DELAY2, JOIN_ACCEPT_DELAY1, JOIN_ACCEPT_DELAY2.

Command	Item	Comments
AT+DELAY=RX1, ms	RECEIVE_DELAY1	RX window 1 delay time
AT+DELAY=RX2, ms	RECEIVE_DELAY2	RX window 1 delay time
AT+DELAY=JRX1, ms	JOIN_ACCEPT_DELAY1	Join accept RX window 1 delay time
AT+DELAY=JRX2, ms	JOIN_ACCEPT_DELAY2	Join accept RX window 2 delay time

Table 6-7 LoRaWAN Delay Items

Format:

```

// Query delay settings
AT+DELAY
AT+DELAY?
AT+DELAY=?

// Set delay
AT+DELAY=RX1, 1000 // Unit: ms
AT+DELAY=RX2, 2000
AT+DELAY=JRX1, 5000
AT+DELAY=JRX2, 6000
    
```

Return:

```

+DELAY RX1, 1000
+DELAY RX2, 2000
+DELAY JRX1, 5000
+DELAY JRX2, 6000
    
```

Revision

- V2.5 2016-01-11
- + Combine the AT command descriptions with HW informations
- V2.4 2015-12-03
- + Sync to FW v1.9.1
- V2.3 2015-11-26
- + Maximum payload size 255 bytes
 - + Add AT+DELAY command
 - + AT+DR=CUSTOM command FSK support
- V2.1 2015-11-24
- + Fix typo
 - + Remove all tedious <CR><LF>
- V2.0 2015-11-18
- + Add RXWIN1 command
 - + Add RXWIN2 SF and BW format command
 - + Add AT+TEST=RFCFG command
 - + Update DR, supports customized data rate scheme
 - + Update doc for LoRaWAN mode firmware V1.8.0
- V1.6 2015-09-11
- + AT+DR=BAND, AT+TEST=RSSI
 - + Update doc for LoRaWAN mode firmware V1.6.8
- V1.5 2015-09-04
- + Add "LOWPOWER" command to enable LowPower Mode
 - + Add commands CH, PORT, JOIN, UART
 - + Update ID, DR, TEST,
 - + Update doc for LoRaWAN mode firmware V1.6.0
- V1.2 2015-06-04
- + Add "CLASS" command to enable LoRaWAN Class C
 - + Update doc for LoRaWAN mode firmware V1.2.6
- V1.1 2015-05-14
- + Update "2.4 Error"
 - + Fix typo
 - + Add content about LoRaWAN output power
 - + Update doc for LoRaWAN mode firmware V1.2.4

V1.0 2015-05-09

- + Use new template
- + Doc is for LoRaWAN mode firmware V1.1.0

Please Read Carefully:

Information in this document is provided solely in connection with RisingHF products. RisingHF reserve the right to make changes, corrections, modifications or improvements, to this document, and the products and services described herein at any time, without notice.

All RisingHF products are sold pursuant to RisingHF's terms and conditions of sale.

Purchasers are solely responsible for the choice, selection and use of the RisingHF products and services described herein, and RisingHF assumes no liability whatsoever relating to the choice, selection or use of the RisingHF products and services described herein.

No license, express or implied, by estoppel or otherwise, to any intellectual property rights is granted under this document. If any part of this document refers to any third party products or services it shall not be deemed a license grant by RisingHF for the use of such third party products or services, or any intellectual property contained therein or considered as a warranty covering the use in any manner whatsoever of such third party products or services or any intellectual property contained therein.

UNLESS OTHERWISE SET FORTH IN RISINGHF'S TERMS AND CONDITIONS OF SALE RisingHF DISCLAIMS ANY EXPRESS OR IMPLIED WARRANTY WITH RESPECT TO THE USE AND/OR SALE OF RisingHF PRODUCTS INCLUDING WITHOUT LIMITATION IMPLIED WARRANTIES OF MERCHANTABILITY, FITNESS FOR A PARTICULAR PURPOSE (AND THEIR EQUIVALENTS UNDER THE LAWS OF ANY JURISDICTION), OR INFRINGEMENT OF ANY PATENT, COPYRIGHT OR OTHER INTELLECTUAL PROPERTY RIGHT.

RISINGHF PRODUCTS ARE NOT DESIGNED OR AUTHORIZED FOR USE IN: (A) SAFETY CRITICAL APPLICATIONS SUCH AS LIFE SUPPORTING, ACTIVE IMPLANTED DEVICES OR SYSTEMS WITH PRODUCT FUNCTIONAL SAFETY REQUIREMENTS; (B) AERONAUTIC APPLICATIONS; (C) AUTOMOTIVE APPLICATIONS OR ENVIRONMENTS, AND/OR (D) AEROSPACE APPLICATIONS OR ENVIRONMENTS. WHERE RISINGHF PRODUCTS ARE NOT DESIGNED FOR SUCH USE, THE PURCHASER SHALL USE PRODUCTS AT PURCHASER'S SOLE RISK, EVEN IF RISINGHF HAS BEEN INFORMED IN WRITING OF SUCH USAGE, UNLESS A PRODUCT IS EXPRESSLY DESIGNATED BY RISINGHF AS BEING INTENDED FOR "AUTOMOTIVE, AUTOMOTIVE SAFETY OR MEDICAL" INDUSTRY DOMAINS ACCORDING TO RISINGHF PRODUCT DESIGN SPECIFICATIONS. PRODUCTS FORMALLY ESCC, QML OR JAN QUALIFIED ARE DEEMED SUITABLE FOR USE IN AEROSPACE BY THE CORRESPONDING GOVERNMENTAL AGENCY.

Resale of RisingHF products with provisions different from the statements and/or technical features set forth in this document shall immediately void any warranty granted by RisingHF for the RisingHF product or service described herein and shall not create or extend in any manner whatsoever, any liability of RisingHF.

RisingHF and the RisingHF logo are trademarks or registered trademarks of RisingHF in various countries.

Information in this document supersedes and replaces all information previously supplied.

The RisingHF logo is a registered trademark of RisingHF. All other names are the property of their respective owners.

© 2016 RISINGHF - All rights reserved

<http://www.risinghf.com>

FEDERAL COMMUNICATIONS COMMISSION (FCC) STATEMENTS

The lora Gateway Module complies with Part 15 of the United States of America FCC rules and regulations. The Original Equipment Manufacturer (OEM) must comply with the FCC certification requirements.

15.21 Any changes or modifications made to the module without the manufacturer's approval could void the user's authority to operate the module.

15.105(b) This equipment has been tested and found to comply with the limits for a Class B digital device, pursuant to part 15 of the FCC rules. These limits are designed to provide reasonable protection against harmful interference in a residential installation. This equipment generates, uses and can radiate radio frequency energy and, if not installed and used in accordance with the instructions, may cause harmful interference to radio communications. However, there is no guarantee that interference will not occur in a particular installation. If this equipment does cause harmful interference to radio or television reception, which can be determined by turning the equipment off and on, the user is encouraged to try to correct the interference by one or more of the following measures:

- Reorient or relocate the receiving antenna.
- Increase the separation between the equipment and receiver.
- Connect the equipment into an outlet on a circuit different from that to which the receiver is connected.
- Consult the dealer or an experienced radio/TV technician for help.

PLEASE NOTE THE MODULE OPERATION IS SUBJECT TO THE FOLLOWING TWO CONDITIONS:

1. This device may not cause harmful interferences.
2. This device must accept any interference received, including interference that may cause undesired operation.

RADIATION EXPOSURE STATEMENT

This equipment complies with FCC radiation exposure limits set forth for an uncontrolled environment. End users must follow the specific operating instructions for satisfying RF exposure compliance. This transmitter must not be co-located or operating in conjunction with any other antenna or transmitter, and the end product must have a separation distance of at least 20cm from all persons. With the documented max output power the module meets the FCC SAR Exemption to comply with any applicable RF exposure requirements in its final configuration.

ORIGINAL EQUIPMENT MANUFACTURER (OEM) NOTES

- The OEM must certify the final end product to comply with unintentional radiators (FCC Sections 15.107 and 15.109) before declaring compliance of the final product to Part 15 of the FCC rules and regulations. Integration into devices that are directly or indirectly connected to AC lines must add with Class II Permissive Change.
- The OEM must comply with the FCC labeling requirements. If the module's label is not visible when installed, then an additional permanent label must be applied on the outside of the finished product which states: "Contains transmitter module FCC ID: 2AJUZ76052". Additionally, the following statement should be included on the label and in the final product's user manual: "This device complies with Part 15 of the FCC Rules. Operation is subject to the following two conditions: (1) This device may not cause harmful interferences, and (2) this device must accept any interference received, including interference that may cause undesired operation."
- The module is limited to installation in mobile or fixed applications. Separate approval is required for all other operating configurations, including portable configuration with respect to Part 2.1093 and different antenna configurations.
- A module or modules can only be used without additional authorizations if they have been tested and granted under the same intended end-use operational conditions, including simultaneous transmission operations. When they have not been tested and granted in this manner, additional testing and/or FCC application filing may be required. The most straightforward approach to address additional testing conditions is to have the grantee responsible for the certification of at least one of the modules submit a permissive change application. When having a module grantee file a permissive change is not practical or feasible, the following guidance provides some additional options for host manufacturers. Integrations using modules where additional testing and/or FCC application filing(s) may be required are: (A) a module used in devices requiring additional RF exposure compliance information (e.g., MPE evaluation or SAR testing); (B) limited and/or split modules not meeting all of the module requirements; and (C) simultaneous transmissions for independent collocated transmitters not previously granted together.

This Module is Limited modular approval, it is limited to OEM installation ONLY.

Change another host devices or Integration into different devices must add with Class II Permissive Change.

Additional measurements (15B) and/or equipment authorizations (e.g Verification) may need to be addressed depending on co-location or simultaneous transmission issues if applicable.

(OEM) Integrator is reminded to assure that these installation instructions will not be made available to the end user of the final host device.